

## Model PC420A Series Acceleration Loop Powered Sensors (LPS™) with Dynamic Vibration Output



### FEATURES:

- Peak equivalent, True RMS or True Peak output
- Corrosion resistant
- Hermetic seal
- ESD protection
- Overload protection
- Reverse wiring protection
- Dynamic signal output

The 4-20 mA output of the PC420A Series is proportional to acceleration vibration. An output of 4 mA indicates a level of 0 g or no vibration present. A full-scale reading of 20 mA indicates that the maximum range (Peak or RMS) of vibration is present.

The dynamic output signal is derived from an internal buffered amplifier. The dynamic output requires the 4-20 mA loop be powered. No constant-current supply diode is necessary, the BOV at the dynamic output is developed by the internal amplifier.

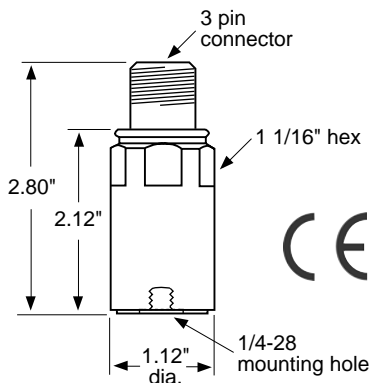

### OUTPUT, 4-20 mA

Full Scale, 20 mA (±5%) .....	see Table 1 on back
Frequency Response:	
±10% .....	10 Hz - 1.0 kHz
±3 dB .....	2 Hz - 2 kHz
Repeatability .....	±2%
Transverse Sensitivity, max. ....	5%

### OUTPUT, Dynamic

	PC420Ax-yy-DA	PC420Ax-yy-DV
Sensitivity (±10%)	100 mV/g	100 mV/inch/sec
Full Scale	20g	1.5 ips @ 1kHz
Frequency Response:		
±3 dB	2.5 Hz - 10 kHz	2.5 Hz - 2.5 kHz
Amplitude Nonlinearity, maximum .....	1%	
Resonant Frequency, mounted, nominal .....	25 kHz	
Transverse Sensitivity, max. ....	5%	

### ELECTRICAL

Power Requirements (Two wire loop power):

Voltage at PC420-series sensor terminals .....	10 VDC min, 30 VDC max
Loop Resistance <sup>1</sup> at 24 VDC, maximum .....	700Ω
Turn on time, 4-20 mA loop .....	< 30 seconds
Dynamic Output, Bias Output Voltage .....	+3.3 VDC, re: connector pin B
Dynamic Output Noise, equivalent g, 2.5 Hz - 10 kHz:	

	PC420Ax-yy-DA	PC420Ax-yy-DV
	2 mg	.002 ips
Grounding .....		Case isolated, internally shielded

### ENVIRONMENTAL

Temperature Range .....	-40 to 85°C
Vibration Limit .....	250 g peak
Shock Limit .....	2,500 g peak
Sealing .....	Hermetic

### PHYSICAL

Sensing Element Design .....	PZT ceramic / shear
Weight .....	162 grams
Case Material .....	316L stainless steel
Mounting .....	1/4 - 28 tapped hole
Output Connector .....	3 pin, MIL-C-5015 style
Mating Connector .....	R6G type
Recommended Cabling .....	J9T3A

### ACCESSORIES SUPPLIED:

- SF6 mounting stud (International customers specify mounting requirements);
- Calibration data (level 2).

**Table 1: PC420Ax-yy-Dz Dual Output Model Number Selection**

x (4-20 mA Output Type)	yy (4-20 mA Full Scale)	z (Dynamic Scale)
R = RMS output, Acceleration	05 = 5 g	A = Acceleration 100mV/g
P = Equivalent Peak output, Acceleration	10 = 10 g	V = Velocity 100mV/ips
TP = True Peak output, Acceleration	20 = 20 g	
	50 = 50 g	

**NOTES:** <sup>1</sup> Maximum loop resistance (R<sub>L</sub>) can be calculated by:

$$R_L \text{ (max resistance)} = \frac{V_{\text{DC power}} - 10 \text{ V}}{20 \text{ mA}}$$

DC Supply Voltage	R <sub>L</sub> (max resistance) <sup>2</sup>	R <sub>L</sub> (minimum wattage capability) <sup>3</sup>
12 VDC	100Ω	1/8 Watt
20 VDC	500Ω	1/4 Watt
24 VDC	700Ω	1/2 Watt
26 VDC	800Ω	1/2 Watt
30 VDC	1.0kΩ	1/2 Watt

CONNECTOR PIN	FUNCTION
SHELL	ground
A	Loop Positive (+)
B	Loop Negative (-), Dynamic Common
C	Dynamic Output

<sup>2</sup> Lower resistance is allowed, greater than 10Ω recommended.

<sup>3</sup> Minimum R<sub>L</sub> wattage determined by: (0.0004 x R<sub>L</sub>).

