

Model PC420A Series Acceleration Loop Powered Sensors (LPS™)



FEATURES:

- Peak equivalent, True RMS or True Peak output
- Corrosion resistant
- Hermetic seal
- ESD protection
- Overload protection
- Reverse wiring protection

The 4-20 mA output of the PC420A Series is proportional to acceleration vibration. An output of 4 mA indicates a level of 0 g or no vibration present. A full-scale reading of 20 mA indicates that the maximum range (Peak or RMS) of vibration is present.

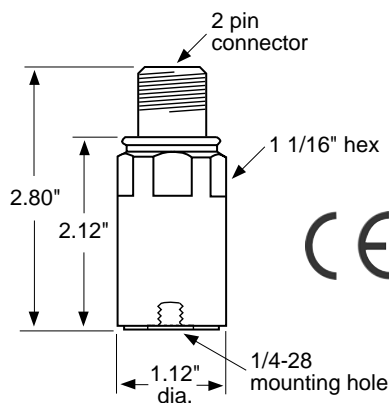

OUTPUT, 4-20 mA

Full Scale, 20 mA (±5%)	see Table 1 on back
Frequency Response:	
±10%	10 Hz - 1.0 kHz
±3 dB	2 Hz - 2 kHz
Repeatability	±2%
Transverse Sensitivity, max.	5%

ELECTRICAL

Power Requirements (Two wire loop power):	
Voltage at PC420-series sensor terminals	10 VDC min, 30 VDC max
Loop Resistance ¹ at 24 VDC, maximum	700Ω
Turn on time, 4-20 mA loop	< 30 seconds
Grounding	Case isolated, internally shielded

ENVIRONMENTAL

Temperature Range	-40 to 85°C
Vibration Limit	250 g peak
Shock Limit	2,500 g peak
Sealing	Hermetic

PHYSICAL

Sensing Element Design	PZT ceramic / shear
Weight	162 grams
Case Material	316L stainless steel
Mounting	1/4 - 28 tapped hole
Output Connector	2 pin, MIL-C-5015 style
Mating Connector	R6 type
Recommended Cabling	J9T2A

CONNECTOR PIN	FUNCTION
SHELL	ground
A	Loop Positive (+)
B	Loop Negative (-)

ACCESSORIES SUPPLIED:

SF6 mounting stud (International customers specify mounting requirements);
Calibration data (level 2).

Table 1: PC420Ax-yy Model Number Selection

x (4-20 mA Output Type)	yy (4-20 mA Full Scale)
R = RMS output, Acceleration	05 = 5 g
P = Equivalent Peak output, Acceleration	10 = 10 g
TP = True Peak output, Acceleration	20 = 20 g

NOTES: ¹ Maximum loop resistance (R_L) can be calculated by:

$$R_L \text{ (max resistance)} = \frac{V_{\text{DC power}} - 10 \text{ V}}{20 \text{ mA}}$$

DC Supply Voltage	R_L (max resistance) ²	R_L (minimum wattage capability) ³
12 VDC	100Ω	1/8 Watt
20 VDC	500Ω	1/4 Watt
24 VDC	700Ω	1/2 Watt
26 VDC	800Ω	1/2 Watt
30 VDC	1.0kΩ	1/2 Watt

² Lower resistance is allowed, greater than 10Ω recommended.

³ Minimum R_L wattage determined by: $(0.0004 \times R_L)$.

Typical Circuit

