

Model PC425xxx-yy-Dz-series 4-20 mA Vibration and Temperature Voltage (LPS®)

FEATURES:

- Peak equivalent or True RMS, or True Peak
- Temperature signal output
- Optional dynamic signal output
- Corrosion resistant
- Hermetic seal
- ESD protection
- Overload protection
- Reverse wiring protection

BENEFITS:

- Choice of output: RMS, Equivalent Peak or True Peak; permits you to choose the sensor that best fits your industrial requirements.
- Provides continuous trending of overall machine vibration
- Can help guide maintenance

The 4-20 mA output of the PC425 Series is proportional to vibration. An output of 4 mA indicates a level of 0 ips or no vibration present for velocity output models and 0 g for acceleration output models. A full-scale reading of 20 mA indicates that the maximum range (RMS, Equivalent Peak or True Peak) of vibration is present.

The Dynamic signal output is an optional addition. Any of the base sensor models can also have dynamic signal output. Adding -DA to a model specifies a dynamic acceleration signal output (100 mV/g). Adding -DV to a model specifies a dynamic velocity signal output (100 mV/ips).

The temperature output of the PC425 Series is in terms of degrees Kelvin (°K), where zero °K = -273°C. The voltage output at 0°C = 2.73 Volts (273°K). The voltage output at 80°C = 3.53 Volts (353°K).

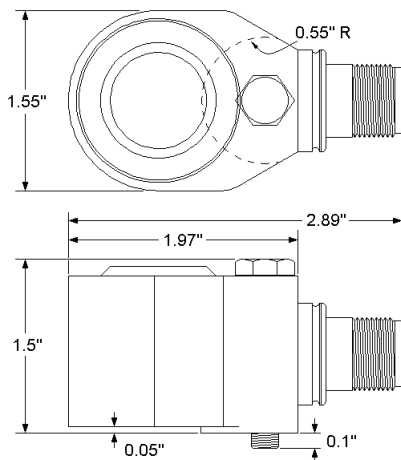

OUTPUT, 4-20 mA

Full Scale, 20 mA (± 5%) see Table 1

Frequency Response:

± 10% 10 Hz - 1.0 kHz

± 3 dB 4 Hz - 2 kHz

Repeatability ± 2%

Transverse Sensitivity, max. 5%

Output, temperature

Temperature Output Sensitivity, ±5°K 10 mV/°K

Temperature Measurement Range..... 223 to 358°K (-50 to 85°C)

OUTPUT, Dynamic (Optional)

PC425xxx-yy-DA PC425xxx-yy-DV

Sensitivity (±10%) 100 mV/g 100 mV / ips

Full Scale 20g, peak 1.5 ips @1kHz

Frequency Response: ± 3 dB 2.5 Hz - 1.8 kHz 2.5 Hz - 1.8 kHz

Amplitude Nonlinearity, maximum 1%

Resonant Frequency, mounted, nominal 21 kHz

Transverse Sensitivity, max. 5%

ELECTRICAL

Power Requirements (Two wire loop power):

Voltage (between pins A & B) 10 VDC min, 30 VDC max

Loop Resistance¹ at 24 VDC, maximum 700Ω

Turn on time, 4-20 mA loop 30 seconds

Grounding Case isolated, internally shielded

Power Requirements (Temperature sensor):⁴

Current 0.4 to 5 mA

ENVIRONMENTAL

Temperature Range..... -40 to 85°C

Vibration Limit 250 g peak

Shock Limit 2,500 g peak

Sealing Hermetic

PHYSICAL

Sensing Element Design PZT ceramic / shear

Weight 320 grams

Case Material 316L stainless steel

Mounting 1/4 - 28 captive bolt

Output Connector MIL-5015 style, 6-pin

Mating Connector R19SLI type

Recommended Cabling J95

CONNECTOR PIN SHELL	FUNCTION
A	Ground
B	Loop Positive (+)
C	Loop Negative (-)
D	Dynamic Signal (optional)
E	Temperature Signal
F	Temperature Common
	Not used

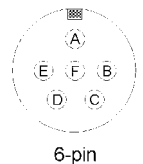

NOTES: ¹ Maximum loop resistance (R_L) can be calculated by:

$$R_L \text{ (max. resistance)} = \frac{V_{DC \text{ POWER}} - 10 \text{ V}}{20 \text{ mA}}$$

DC Supply Voltage	R _L (max resistance) ²	R _L (minimum wattage capability) ³
12 VDC	100Ω	1/8 Watt
20 VDC	500Ω	1/4 Watt
24 VDC	700Ω	1/2 Watt
26 VDC	800Ω	1/2 Watt
30 VDC	1.0kΩ	1/2 Watt

² Lower resistance is allowed, greater than 10Ω recommended

³ Minimum R_L wattage determined by: (0.0004 x R_L)

⁴ The temperature sensor must have a current flow to operate. This current can be provided through constant-current diodes (i.e. Vishay J508, etc.)

Table 1: PC425xxx-yy-Dz Model Number Selection

xxx (4-20 mA Output Type)	-yy (Full Scale)	-Dz (Dynamic Output) ^A	
AR = Acceleration, RMS AP = Acceleration, Equivalent Peak ^B ATP = Acceleration, True Peak ^C	-05 = 5 g (49 m/sec ²) -10 = 10 g (98 m/sec ²) -20 = 20 g (196 m/sec ²)	-DA = Dynamic Acceleration	100 mV/g (10.2 mV/ m/sec ²)
VR = Velocity, RMS VP = Velocity, Equivalent Peak ^B VTP = Velocity, True Peak ^C	-05 = 0.5 i.p.s. (12.8 mm/sec) -10 = 1.0 i.p.s. (25.4 mm/sec) -20 = 2.0 i.p.s. (50.8 mm/sec) -30 = 3.0 i.p.s. (76.2 mm/sec) -50 = 5.0 i.p.s. (127 mm/sec)	-DA = Dynamic Acceleration	100 mV/g (10.2 mV/ m/sec ²)
		-DV = Dynamic Velocity	100 mV/ips (3.94 mV/ mm/sec)
		-DV = Dynamic Velocity	100 mV/ips (3.94 mV/ mm/sec)

^A **Dynamic output is an option on all models.** If dynamic output option is not desired, do not add -DA or -DV to the model number.

^B **Equivalent peak** output is developed based on the true RMS value of vibration. For a pure sine wave, the equivalent peak output is 1.414 times the RMS value.

^C **True peak** output is based on the actual measured peak value using the time waveform and is not based on the RMS calculation.

PC425xxx-yy WIRING

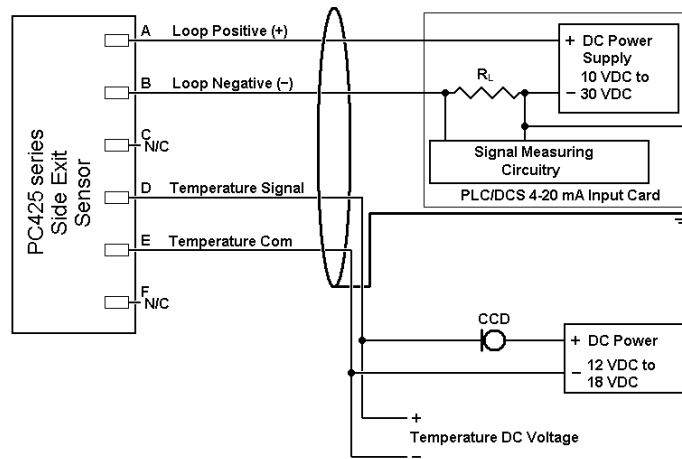

PC425xxx-yy-Dz WIRING

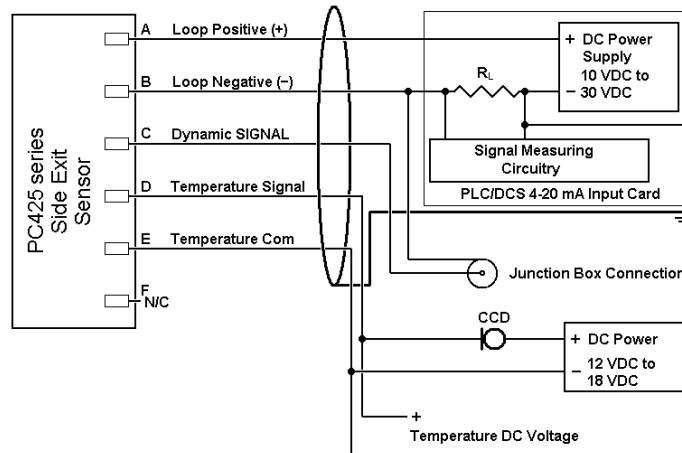

All wire and cable used for installation of the PC425-series sensor should be shielded. Generally accepted instrumentation wiring practice considers the best way to ground the shield is to connect it at the measurement end of the cable. The shield should not be wired to ground at the sensor end of the cable. The Wilcoxon R19SLI type connector leaves the shield unconnected at the sensor end of the cable.

21 Firstfield Road, Gaithersburg, MD 20878 USA
1-800-WILCOXON
Tel 301-330-8811 Fax 301-330-8873
Email sensors@wilcoxon.com
Web www.wilcoxon.com



Due to continued research and development, Wilcoxon Research reserves the right to amend this specification without notice.